

No. 1 CARGO HOLD (FR 193~222)

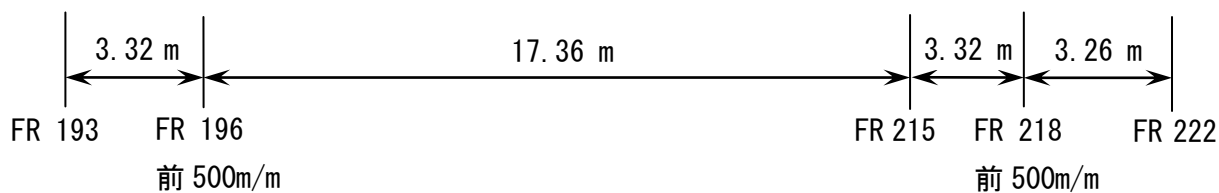

コルゲート

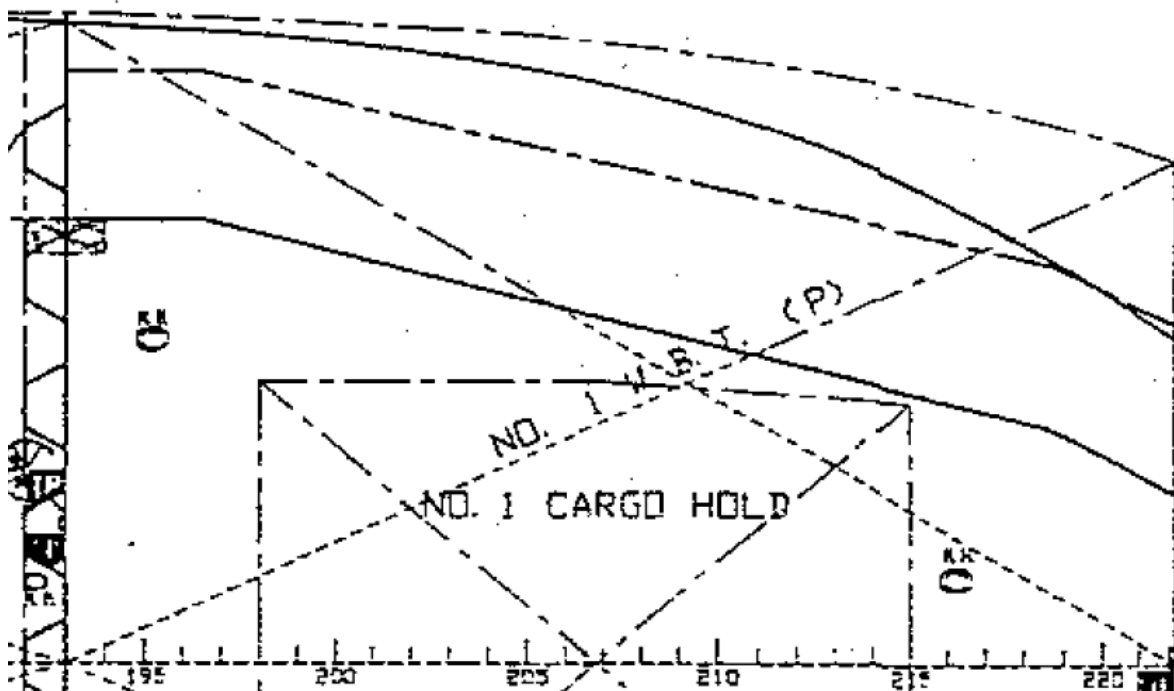
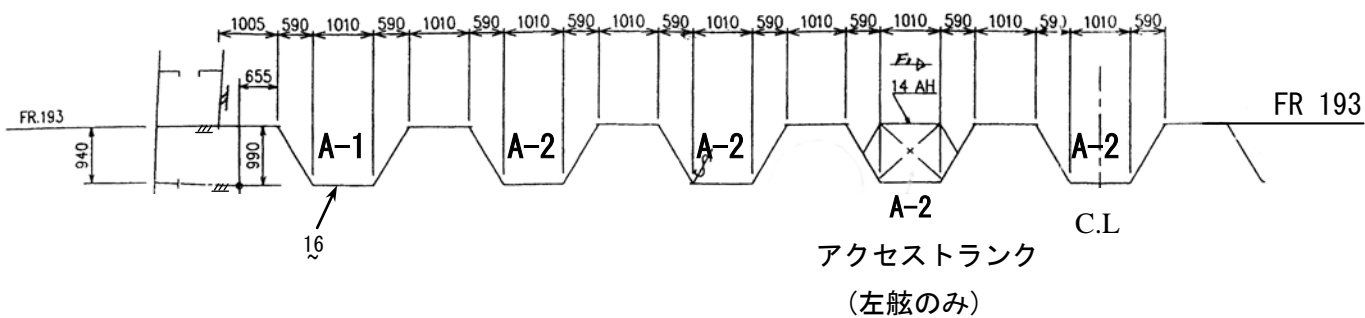

	長さ	x	幅	x	高さ	x	個数
A-1	0.97	x	1.60	x	12.61	x	2
A-2	"	x	"	x	13.52	x	7
アクセスランク	"	x	1.33	x	"	x	-1

NO. 1 CARGO HOLD

容 積	12100.81 m ³
MID. G	-84.69 m
K G	11.37 m
C. L. G.	0.00 m
最大 I	35816.2 m ⁴

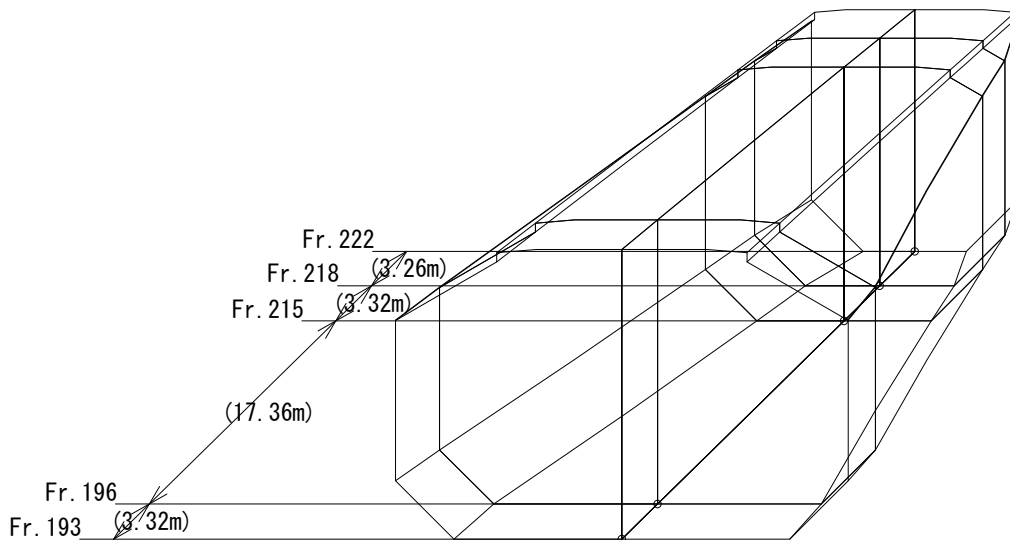

区分	位 置		面 積 (m ²)	K G (m)	C. L. G. (m)	長 さ (m)	容 積 (m ³)
	Fr. No.	距 離 (m)					
1	193	0.00	258.06	10.91	6.93	3.32	1711.39
	194	0.72	257.74	10.93	6.89		
	196	0.50	257.41	10.96	6.86		
2	196	0.50	257.41	10.96	6.86	17.36	7974.16
	205	0.72	230.23	11.33	6.01		
	215	0.00	199.72	11.71	5.13		
3	215	0.00	199.66	11.71	5.13	3.32	1284.31
	216	0.72	193.44	11.78	4.96		
	218	0.50	187.11	11.85	4.78		
4	218	0.50	187.11	11.85	4.78	3.26	1130.95
	220	0.25	173.53	11.98	4.43		
	222	0.00	159.54	12.11	4.08		
合 計							12100.81
容 積 (控除率 = 1.000)							12100.81

$$1 : (258.06 + 4 \times 257.74 + 1 \times 257.41) \times 3.32 / 6 = 1711.39$$

$$2 : (257.41 + 4 \times 230.23 + 1 \times 199.72) \times 17.36 / 6 = 7974.16$$

$$3 : (199.66 + 4 \times 193.44 + 1 \times 187.11) \times 3.32 / 6 = 1284.31$$

$$4 : (187.11 + 4 \times 173.53 + 1 \times 159.54) \times 3.26 / 6 = 1130.95$$

$$12100.81$$

NO. 1 CARGO HOLD

【位置】 FR. 193 後 0.000 m 1 - 1/3

面積	258.06 m ²
K G	10.91 m
C. L. G.	6.93 m

座 標		
No.	W. L.	BRD.
1	1.711	0.000
2	1.711	11.050
3	5.558	14.900
4	16.126	14.900
5	16.126	14.850
6	19.957	8.240
7	20.557	8.240
8	20.775	5.600
9	20.775	0.000
10	1.711	0.000

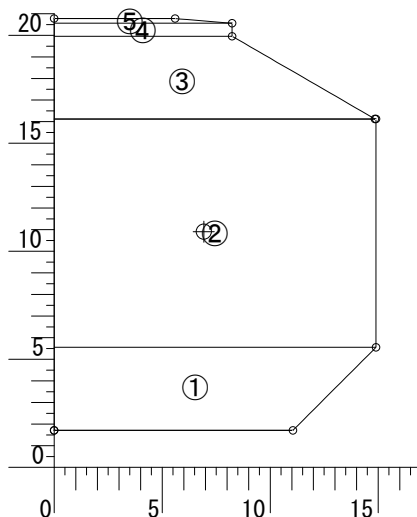

NO.	幅 (m)	高さ (m)	面積 (m ²)
①	$(11.050 + 14.900) / 2 = 12.975$	$(5.558 - 1.711) = 3.847$	49.915
②	14.900	$(16.126 - 5.558) = 10.568$	157.463
③	$(14.850 + 8.240) / 2 = 11.545$	$(19.957 - 16.126) = 3.831$	44.229
④	8.240	$(20.557 - 19.957) = 0.600$	4.944
⑤	$(8.240 + 5.600) / 2 = 6.920$	$(20.775 - 20.557) = 0.218$	1.509

計 258.060

【位置】 FR. 194 後 0.720 m 1 - 2/3

面積	257.74 m ²
K G	10.93 m
C. L. G.	6.89 m

座 標		
No.	W. L.	BRD.
1	1.711	0.000
2	1.711	11.050
3	5.458	14.800
4	16.235	14.800
5	16.235	14.750
6	20.007	8.240
7	20.607	8.240
8	20.825	5.600
9	20.825	0.000
10	1.711	0.000

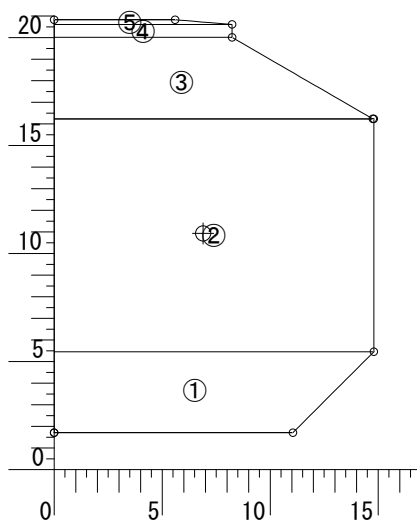

NO.	幅 (m)	高さ (m)	面積 (m ²)
①	$(11.050 + 14.800) / 2 = 12.925$	$(5.458 - 1.711) = 3.747$	48.430
②	14.800	$(16.235 - 5.458) = 10.777$	159.500
③	$(14.750 + 8.240) / 2 = 11.495$	$(20.007 - 16.235) = 3.772$	43.359
④	8.240	$(20.607 - 20.007) = 0.600$	4.944
⑤	$(8.240 + 5.600) / 2 = 6.920$	$(20.825 - 20.607) = 0.218$	1.509

計 257.742