

INCLINING TEST [1]

SHIP'S NAME		INSPECTOR	Mr. TIM
DATE		WIND	BREEZE
PLACE		SPECIFIC GRAVITY OF S.W. ρ_0	1.0220
WEATHER	FINE	TEMPERATE OF SEA WATER	6.5 °C

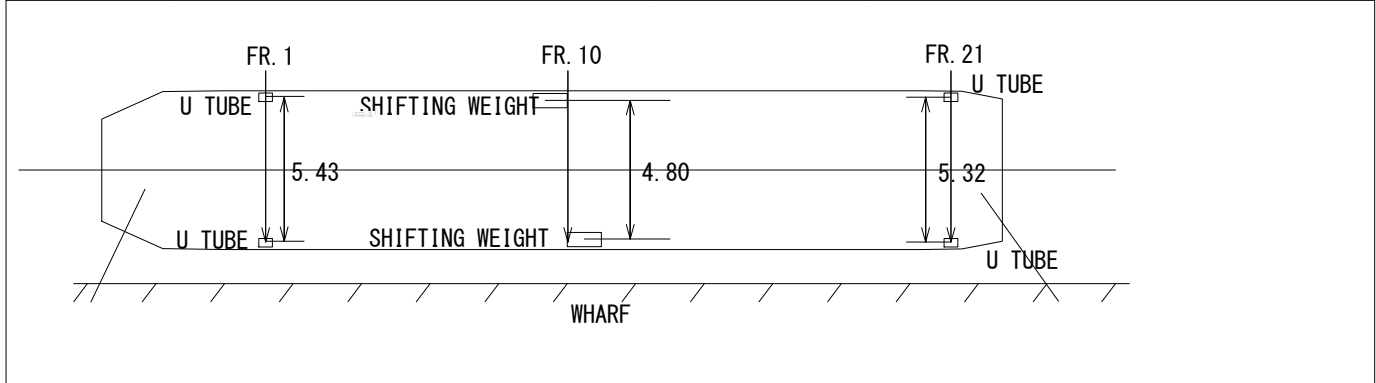

8 5 : H / 8 = G D H'	FORE DRAFT	df (m)	1.418	DRAFT WITH DEFLECTION	$dM \delta = dM + \frac{3}{4} \delta$ (m)	1.463
	MIDSHIP DRAFT	d MID (m)	1.464	DISPT WITH DEFLECTION	WM (t)	75.61
	AFT DRAFT	da (m)	1.510	CENTER OF FLOATATION	MID F (AFT) (m)	0.88
	CORRECTED FORE DRAFT	dF (m)	1.410	TONS PER 1 CM IMMERSION	TPC (t)	0.74
	CORRECTED AFT DRAFT	dA (m)	1.510	DISPT FOR TRIM CORR.	ΔWt (t)	0.56
	MEAN DRAFT	$dM = \frac{dF + dA}{2}$ (m)	1.460	CORRECTED DISPT.	$Wt = WM + \Delta Wt$ (t)	76.17
	TRIM	$T = dA - dF$ (AFT) (m)	0.100	DRAFT ABOVE	d (m)	1.470
	DEFLECTION	$\delta = d \text{ MID} - dM$ (m)	0.004	DISPLACEMENT OF TEST	$W = \frac{\rho_0 WT}{1.025}$ (t)	75.95

= B 7 @ = B = B G T E S T	KIND OF WEIGHT		BLOCK	SHIFTING MOMENT	wy (t-m)	2.02	
	WEIGHT		w (t)	0.42	LENGTH OF U TUBE (FORE)	l1 (m)	5.320
	DISTANCE OF SHIFT		y (m)	4.80	LENGTH OF U TUBE (AFT)	l2 (m)	5.430
	NO.	WEIGHT		FORE		AFT	
		P	S	READING P/S	DIFFERENCE	READING P/S	DIFFERENCE
	1	●	○	445.5 / 388.4	72.1	381.0 / 363.0	65.9
	2		○ ●	416.0 / 431.0		345.8 / 393.7	
	3	●	○	446.9 / 387.8	74.1	384.0 / 358.9	73.0
	4	● ○		475.4 / 341.3	75.0	423.5 / 317.5	80.9
	5	●	○	446.8 / 385.4	72.7	386.5 / 352.4	71.9
6			0.0		0.0		
7			0.0		0.0		
8			0.0		0.0		
9			0.0		0.0		
TOTAL			—	293.9	—	291.7	
MEAN				S1 73.48		S2 72.93	
tan θ				S1/l1 0.01381		S2/l2 0.01343	
MEAN $\tan \theta = \frac{1}{2} \left(\frac{S1}{l1} + \frac{S2}{l2} \right)$			$\frac{1}{2} (0.01381 + 0.01343) = 0.01362$				
GoM = $\frac{wy}{w * \tan \theta}$			$\frac{0.42 \times 4.80}{75.95 \times 0.01362} = \frac{2.02}{1.034} = 1.95 \text{ M}$				

INCLINING TEST [2]

SHIP'S NAME	MT12-1301			INSPECTOR	Mr. TIM KO KO SUPERINTENDENT			
TEST CONDITION	GGo	$\frac{\sum \rho 1}{W}$	0.00 M	TANK NAME	MOMENT OF INERTIA (I)	SPECIFIC GRAVITY (ρ)	MOMENT ($\rho 1$)	
	GM	GoM + GGo	1.95 M		M4		T-M	
	TKM		3.31 M		M4		T-M	
	KG		1.36 M		M4		T-M	
	MTC		0.83 T-M		M4		T-M	
	BG	$\frac{MTC * 100T}{W}$	0.11 M		M4		T-M	
	MID B	[FORE]	-0.46 M		M4		T-M	
	MID G	[FORE]	-0.35 M	[TOTAL]	-	-	T-M	
ROLLING PERIOD	DATE	6TH A5M 2013		WEIGHT (BLOCK)				
	PLACE	BINHAI SHIPYARD WHARF		SAND BAG				
	WEATHER	FINE						
	WIND							
	SEA WATER CONDITION	BREEZE		NO.	ROLLING ANGLE	ROLLING NO.	TIME (sec)	MEAN OF TIME (sec)
	SPECIFIC GRAVITY OF SEA WATER $\rho 0$	1.0220		1				
	DISPLACEMENT C_{HGH}	w	75.95 Ton	2				
	S. G. OF DISPLACEMENT	$WT = \frac{1.025 * W}{\rho 0}$	76.17 Ton	3				
	DRAFT ABOVE		1.47 M	4				
	TKM		3.31 M	5				
	KG		1.36 M	TOTAL				
	GM		1.95 M	ROLLING PERIOD				TS (sec)
GGo		0.00 M	BREATH OF SHIP			B. MLD (M)	5.60	
GoM	$GM - GGo$	1.95 M	$\frac{K}{B} = \frac{TS \sqrt{GoM}}{2.01 B} = \frac{\sqrt{1.95}}{2.01 * 5.60}$					
LIGHT WEIGHT	ITEM	WEIGHT (Ton)	MID G (M)		MOMENT (T - M)		KG (M)	MOMENT (T - M)
			FORE	AFT	FORE	AFT		
	TEST CONDITION	75.95	-0.35		-26.58		1.36	103.29
	WEIGHT TO BE REMOVE	-15.12	-4.76			71.91	1.54	-23.24
	WEIGHT TO BE ADDED	0.08	-2.00		-0.16		6.00	0.48
	TOTAL	60.91		0.74	-26.74	71.91	1.32	80.53
						45.17		
	DISPLACEMENT	W	60.91 Ton	BG				1.47 M
	DRAFT	d	1.254 M	MTC				0.53 T-M
	TKM		3.34 M	TRIM	$T = \frac{W * BG}{100 * MTC}$		[AFT]	1.689 M
KG		1.32 M	MID F		[AFT]		0.03 M	
GM		2.02 M	FORE DRAFT	$d - \frac{T}{L} (\frac{L}{2} + MID F)$		dF	0.40 M	
MID B	[FORE]	-0.73 M	AFT DRAFT	$d + \frac{T}{L} (\frac{L}{2} - MID F)$		dA	2.10 M	
MID G	[AFT]	0.74 M	MEAN DRAFT		dM		1.25 M	

() : SHOWS THE VALUE OF SISTER SHIP

